

## **Contents :-**

1. STUMPS
2. BRACING
3. CONNECTORS
4. DURABILITY
5. TECHNICAL SUPPORT
6. ENGINEERING & CERTIFICATION
7. JOB DESIGN
8. FIXINGS
9. AVAILABILITY
10. APPLICATION DETAILS

# Steel -MAX

Building Systems  
[www.steelmax.com.au](http://www.steelmax.com.au)  
**"The right choice"**

## Steel-MAX companion products to suit TIMBER floor framing.

### System components

Designed for TIMBER bearers & joists.

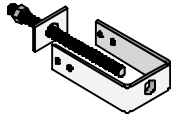

### Bracing brackets

50, 75 & 90mm

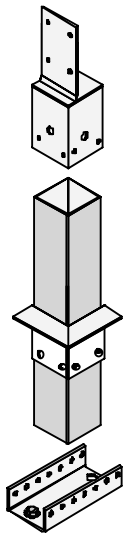

### SMART stumps

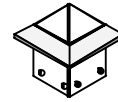

### Post sleeves

75 & 90mm

### Stump tops

90 mm

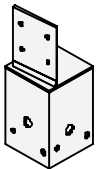

T-90

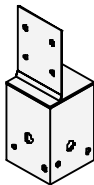

T-150

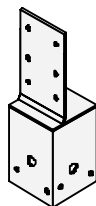

T-200

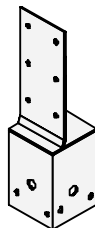

T-250



Screw tops



MT-LSB

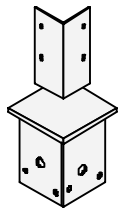

Mult-tops

75 mm

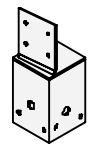

T-75

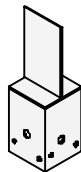

CT-75 / 180

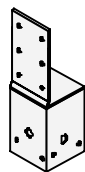

T-75 / 180

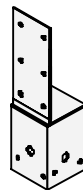

T-75 / 230

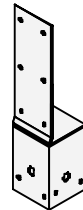

T-75 / 280

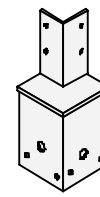

Special 50mm set-back Mult-tops (to suit 90mm stumps)

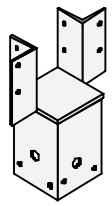

### Stump bases

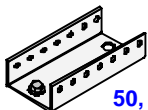

50, 75 & 90mm

Stump base fittings  
 ( Also used as heavy duty connector brackets.)

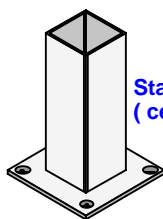

Standard (centre)

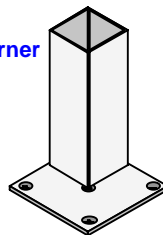

Corner

Moment base plates

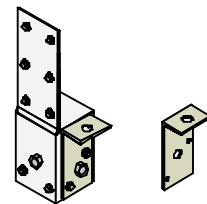

### Stitch bolt brackets

### Connector brackets

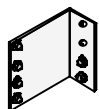

"L" bracket

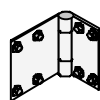

"H" hinge bracket



Joist connector  
 40x40x200



Joist connector  
 50x50x295

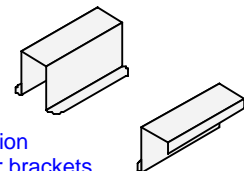

Insulation hanger brackets.

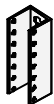

B-50, B-75 & B-90  
 Heavy duty bracket

### Tophats

### System components

Designed for TIMBER bearers & joists.

## 1. SMART STUMPS

Steel-MAX has designed a special range of 75mm & 89/90mm stumps specifically to suit Timber bearers.

- STUMP TUBE:-

The stump tube is either 75x75, 89x89 or 90x90 Gal. SHS and will vary in wall thickness to suit load requirements.

- STUMP BASES:-

Stump bases are in the form of a "U" shaped bracket, for multi-position and multi-angle connection to footings. Special "Moment Base plates" are available for mezzanine floors and where maximum bracing stability is required.

- STUMP TOPS:-

Stump tops fit any wall thickness tube and are telescopically height adjustable up to 75mm. They have vertical "fin plates" to suit from 90mm to over 300mm high timber bearers. They provide maximum support and hold-down, through the bearer's web, giving the bearers lateral stability.

Special screw adjustable tops are also available and are particularly useful for reactive soil conditions.

Centre fin tops, to suit 75mm stumps, can be used between back-to-back bearers or beams.

Multi-top stumps are also available for applications where bearers can be joined at "T" intersections and 90 deg corners.

Flush fitting tops are used to keep 50mm bearers flush with face of stumps and are great for verandah decks.

- POST SLEEVES:-

Post sleeves may be used to carry bearers which need to be fixed to the face of a verandah post, or a higher stump which continues up to support a different level floor, such as in split levels.

## 2. BRACING:-

"U" shaped bracing brackets are connected to stumps and bearers, to carry either 12mm or 16mm threaded bracing rod, to form sub-floor cross bracing sets. They yield up to 15 kN or 22 kN capacities respectively.

## 3. CONNECTORS:-

- "L" fixed angle brackets may be used at 90 deg member connections in a variety of applications. They are also useful when connecting trimmers around stair voids and "in-plane" joists.
- Hinged "H" brackets can be used at angled connections, similar to the "L" brackets.
- Joist connector brackets are in the form of an angle, which are usually fixed vertically to both the bearers & joists.

They help support both members and provide good hold-down and lateral stability to joists. They are available in 200mm and 295mm lengths.

## 4. DURABILITY:-

All Steel-MAX products have corrosion protection, such as Dacrotising ( refer to web site at: <http://www.dacro.co.kr/eng-3.htm> ) as well as Galvanizing and Galvabond finishes. Refer also to the Steel-MAX corrosion protection recommendations.

## 5. TECHNICAL SUPPORT:-

Contact Steel-MAX via the web site, email, phone or fax; or ask your timber supplier.

## 6. ENGINEERING:-

Engineering design and certification is provided by H.R. Design Group P/L (Hunt Robinson Engineers) for the Steel-MAX products for use with timber sections, in a floor framing system.

A copy of the standard letter of certification is available from the Steel-MAX web site.

Steel-MAX does not provide individual job certification, footing or sub-floor bracing designs, or certificates of compliance. These are generally site specific and should be provided by the project engineer.

## **7. JOB DESIGN:-**

Refer to your timber supplier to determine the most suitable timber member sizes for your project, or ask your supplier representative for assistance from Steel-MAX to offer a floor design solution for your project, including all necessary Steel-MAX companion products to complete the floor system.

## **8. FIXINGS:-**

Refer to the Steel-MAX load capacity tables on page 14 , (provided by the H.R. Group) and have your project engineer specify your individual job requirements. However; for uniformly loaded domestic applications, consider the following as a guide only :-

Stump bases to stump tube = 6 / 14 g hex teks ( 3 in each face )

Stump tops to stump tube = 8 / 14 g teks up to 8 m2 of floor area carried by the stump, then 1 / screw per m2 or 1/M12 bolt per 5 m2 of area extra over the first 8 m2.

Sleeves to tube = 8 / 14 g teks per sleeve.

Bracing brackets = 4 / 14 g teks per brackets for 12mm rod and 1 / M16 bolt per bracket for 16mm rod.

"L" & "H" connector brackets = 8 / 10 g teks for joist to bearer connections and 8 / 14 g teks for bearer to bearer connections.

Joist connector brackets = use 6 / screws per brackets ( 3 in each member )

## **9. AVAILABILITY:-**

All necessary Steel-MAX "Companion products" to Timber Floor Framing Systems are available from your participating timber supplier, or by contacting **Steel-MAX Distribution** by calling (07) 3831 5444 or Mob: 0438 748 381 Fax: 07 3831 5666 email [distribution@steelmax.com.au](mailto:distribution@steelmax.com.au)

## **10. APPLICATION DETAILS:-**

The following diagrams are suggested methods of using Steel-MAX "Companion products" in relation to timber sections for a restricted number of common construction applications. Additional information and special designs are also available from Steel-MAX.

The information contained within this document or any other provided by Steel-MAX does not represent, form or replace your timber supplier's official documentation, relating to the any proprietary floor framing system.

All information shown, enclosed and contained within this and associated documents represents suggested methods of using Steel-MAX components in conjunction with timber sections and may not suit your particular job requirements and application.

We offer design solutions as a suggestion, for the consideration of the customer and his project engineer.

It is imperative that the customer's project engineer looks at the suggested details and either incorporates them into his whole job structural design, or alters them to suit his requirements, for the project.

It is always possible that there could be influencing elements within the structure, that we are not aware of, which could effect and alter the following suggested details and information..

# Steel - MAX

Building Systems  
www.steelmax.com.au

**"The right choice"**

## **Steel-MAX companion products to suit TIMBER floor framing.**

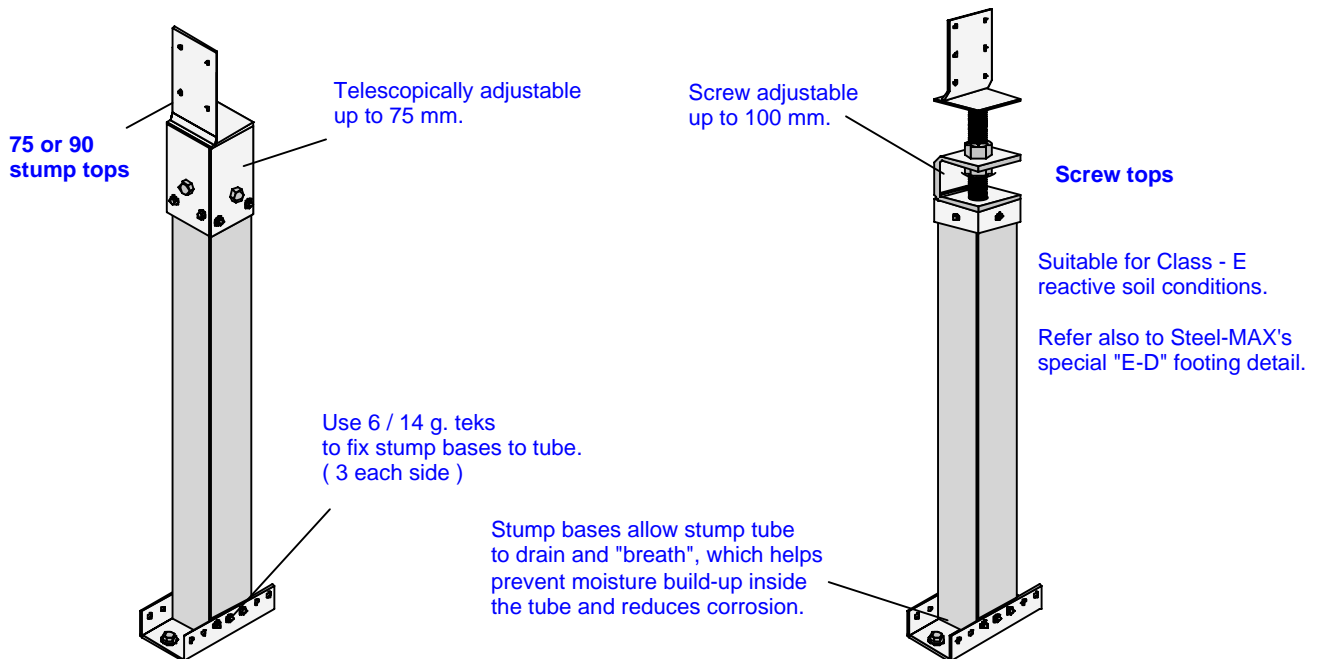

### **Detail:- 1**

### **S-75 or S-90 "Smart Stumps"**

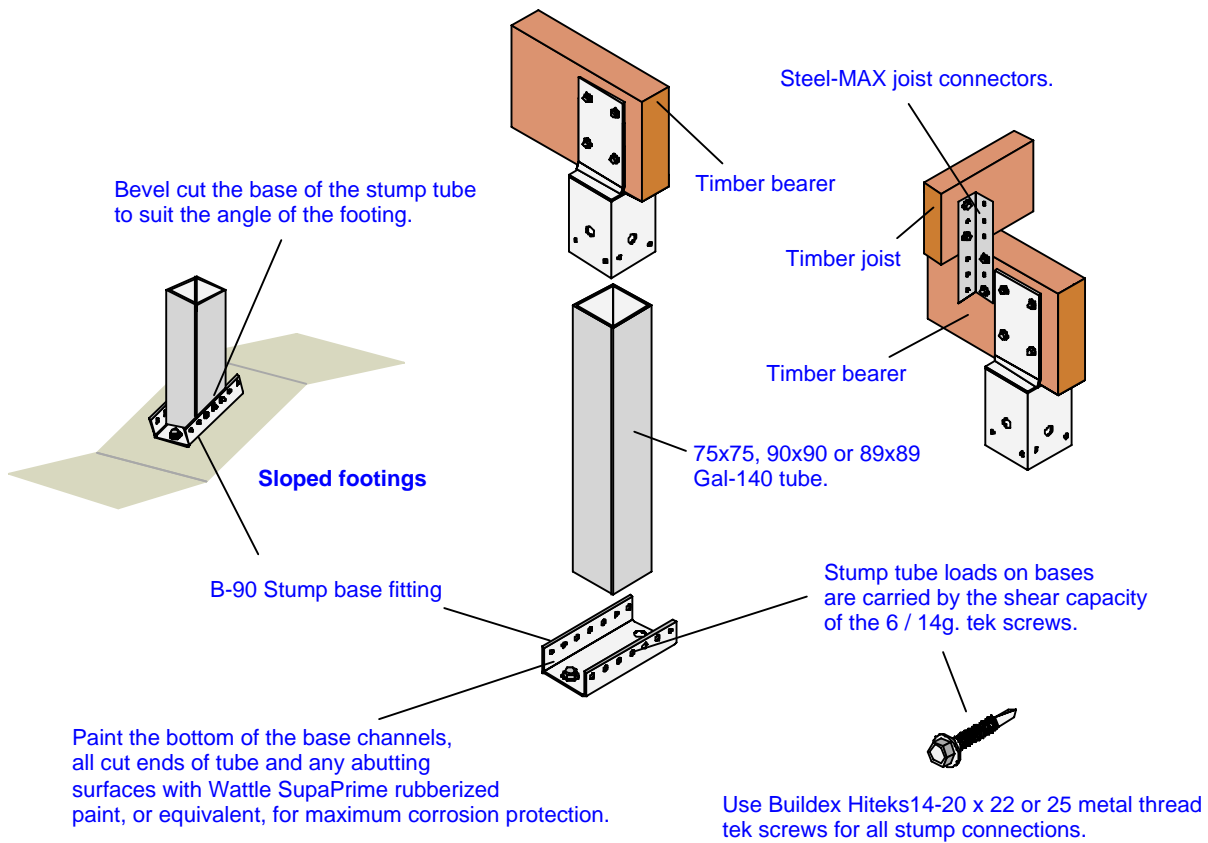

### **Detail:- 2**

# Steel - MAX

Building Systems  
www.steelmax.com.au

**"The right choice"**

**Steel-MAX companion products  
to suit TIMBER floor framing.**

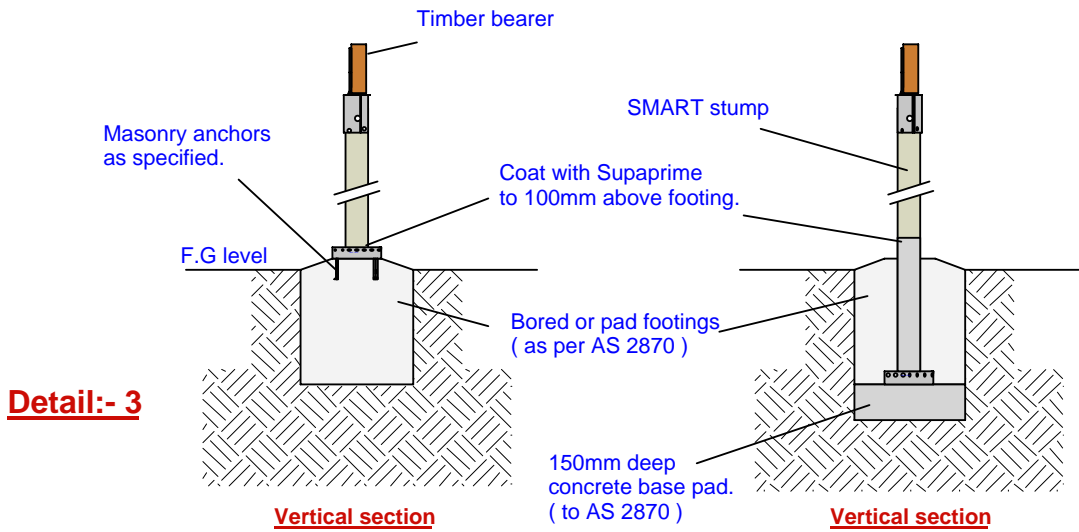

**Detail:- 3**

## **FOOTINGS**

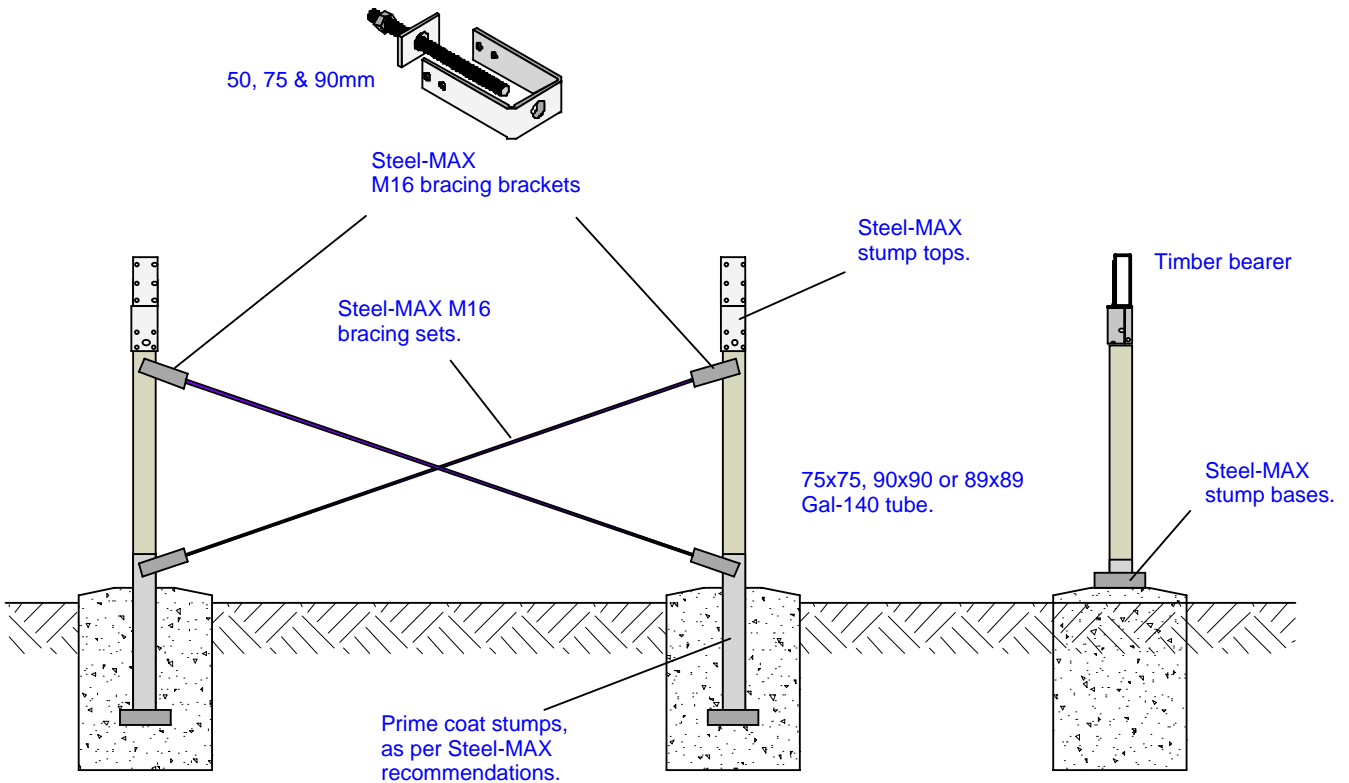

## **BRACING**

Refer to the Steel-MAX web site  
for bracing values of cast-in stumps  
and cross bracing.

**Detail:- 4**

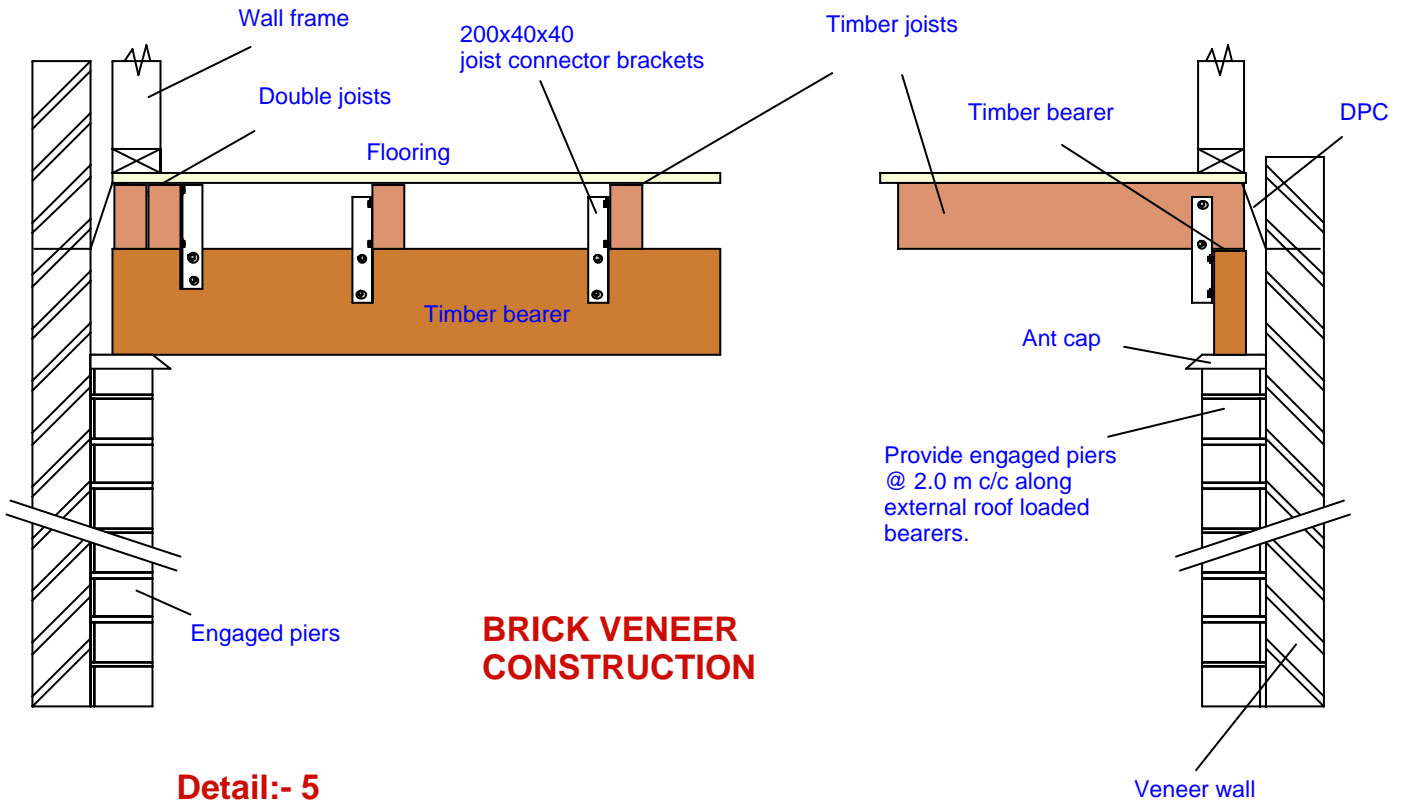

## BRICK VENEER CONSTRUCTION

**Detail:- 5**

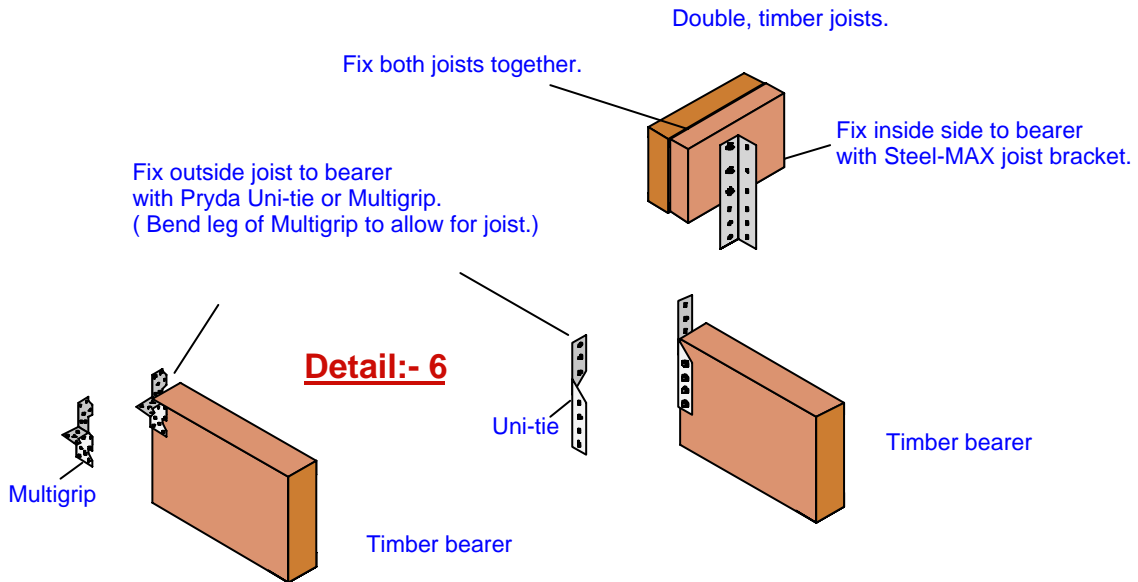

**Detail:- 6**

## Double joists under roof loaded ext. walls.

Termite protection.

Smart stumps comply with AS 3660.1 ( termite code ) Clause 4.2.2 and must remain exposed for ongoing inspection.

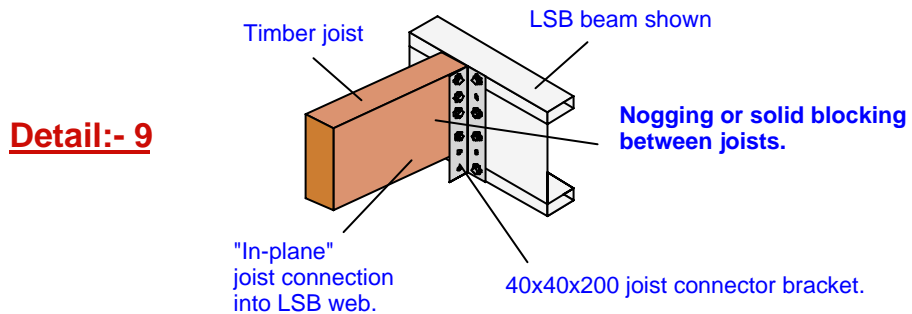
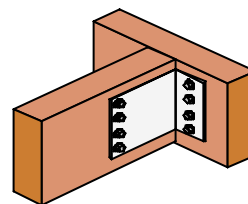
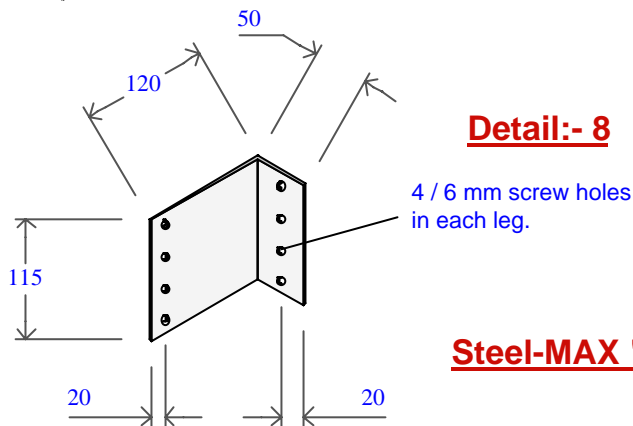
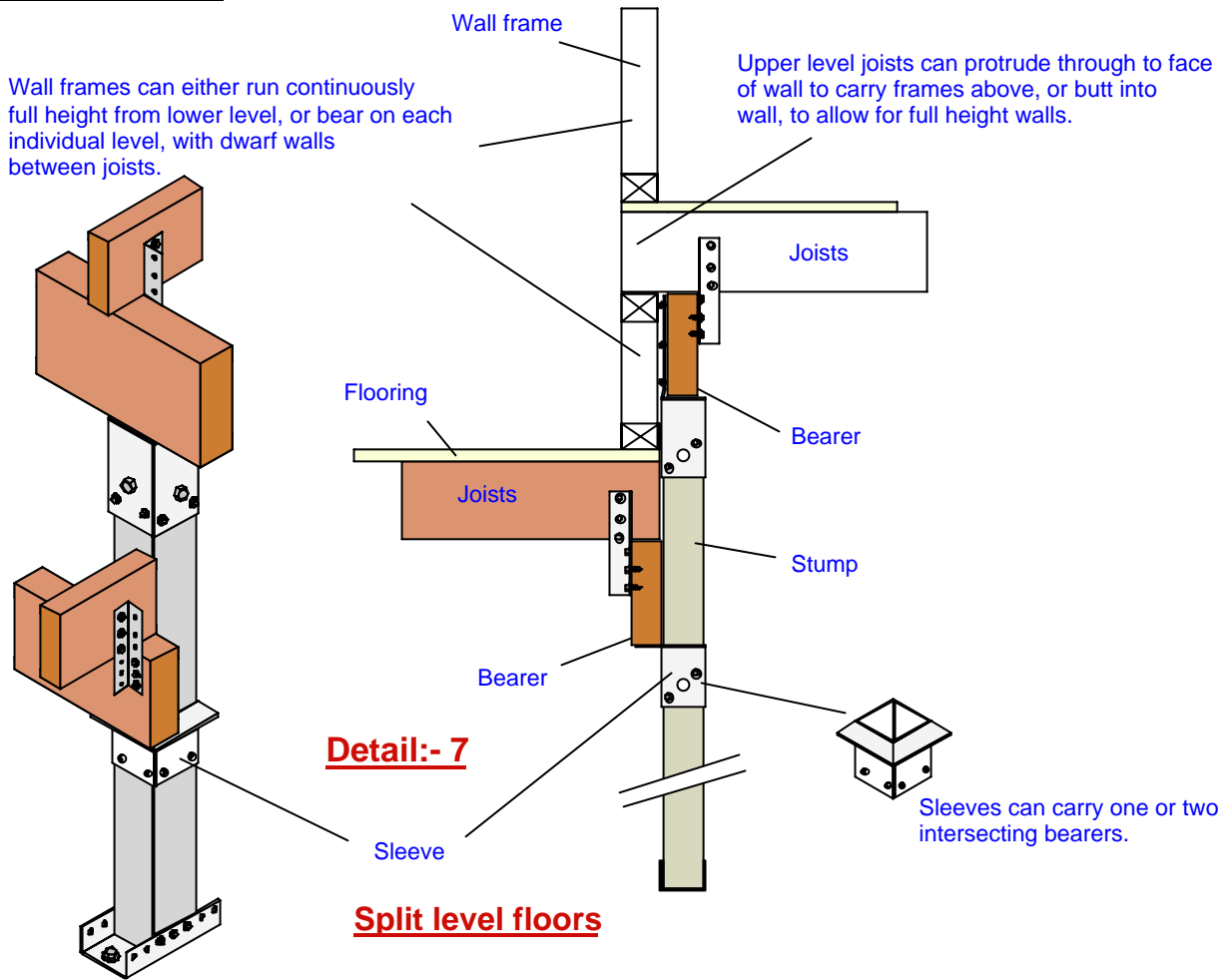

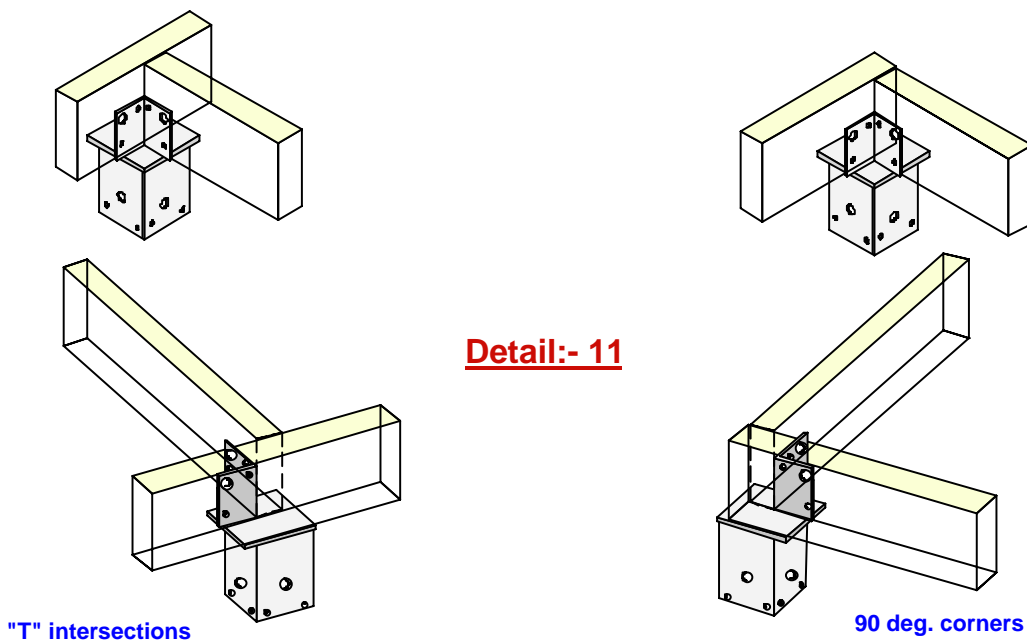
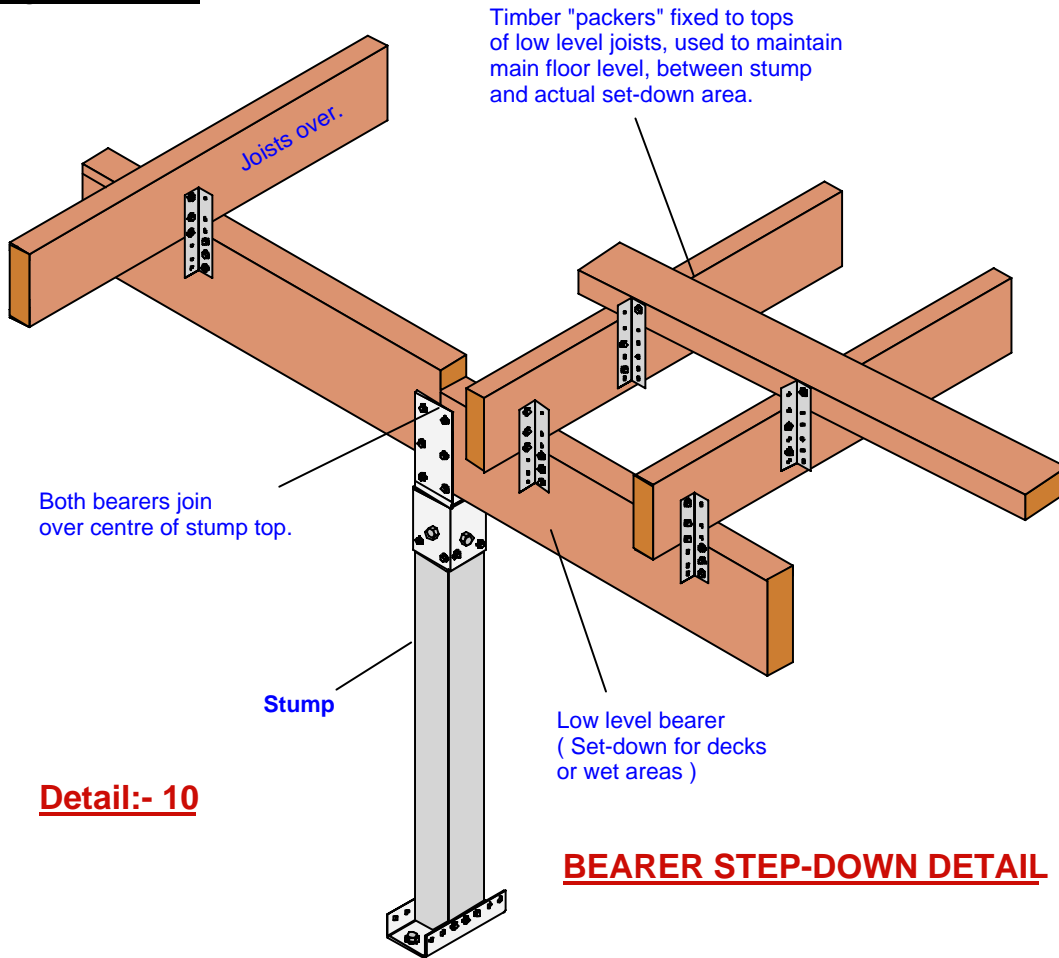

**"Multi-top" stump tops  
( also available in screw tops )**

# Steel - MAX

Building Systems  
www.steelmax.com.au

**"The right choice"**

## **Steel-MAX companion products to suit TIMBER floor framing.**

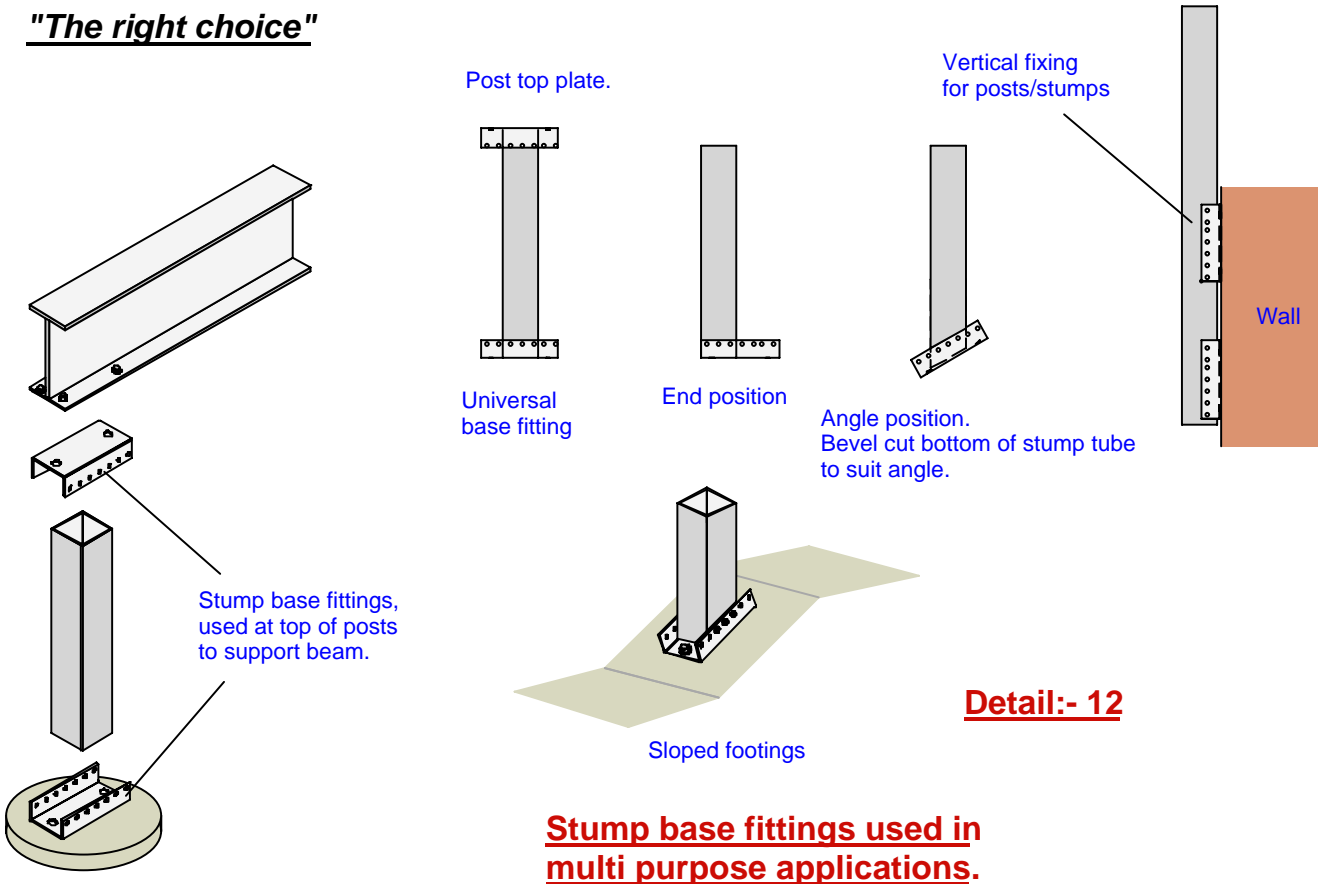

### **Stump base fittings used in multi purpose applications.**

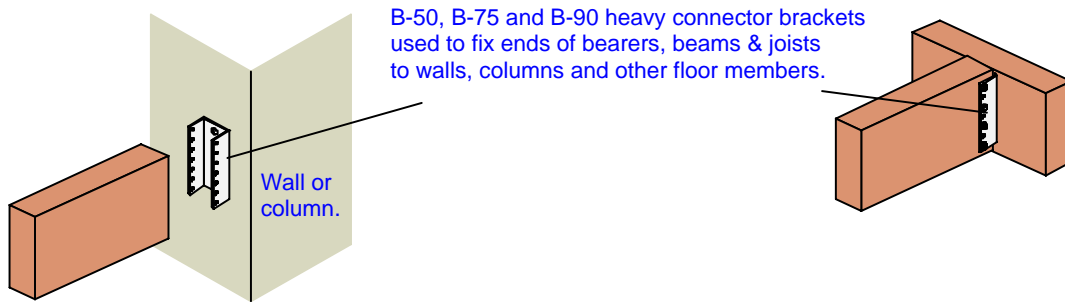

### **B-50, B-75 or B-90 heavy duty connector brackets.**

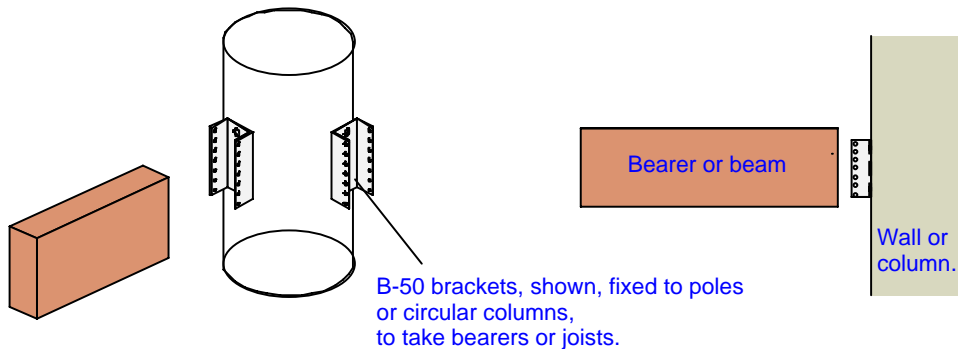

### **Detail:- 13**

# Steel - MAX

Building Systems  
www.steelmax.com.au

**"The right choice"**

## **Steel-MAX companion products to suit TIMBER floor framing.**

"Jack" joists can be splayed or mitre cut.

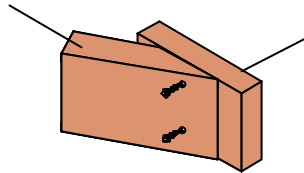

Angled, in-plane timber members, joined at verandah hips or similar connections.

### **Detail:- 14**

## **Angled verandah "Hip" and similar connections**

Timber bearers, beams or joists

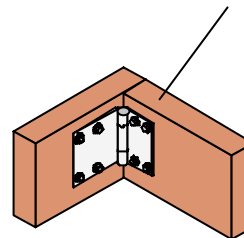
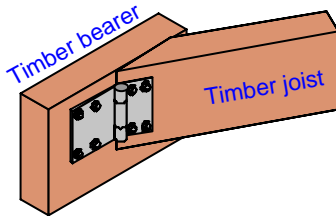

### **Detail:- 15**



Timber in-plane at angled intersections, joined with hinged "H" hip brackets.



Hinged connector bracket.

## **Hinged "H" ( hip ) brackets.**

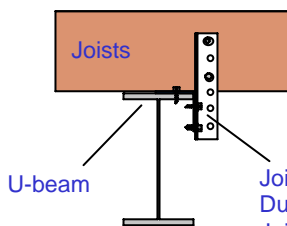

Joists are fixed to 75x75x4.0 DuraGal angle, with 40x40x200 Joist connector bkts. The angle is fixed to top flange of U-beam with Series 500 teks. ( or bolted, as specified.)

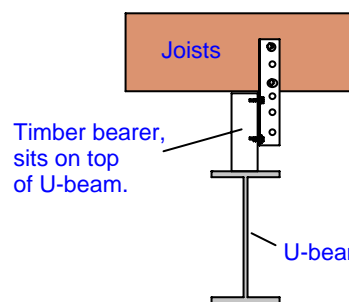

U-beam used as a stiffener beam below continuous timber bearer.

Bearers can also run at 90 deg. to beams.

### **Detail:- 16**

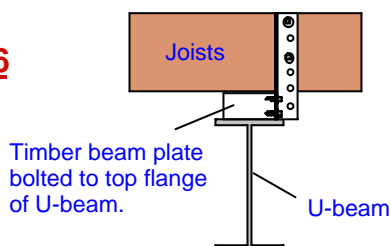

## **U-beam connections**

# Steel - **MAX**

Building Systems

www.steelmax.com.au

**"The right choice"**

**Steel-MAX companion products to suit TIMBER floor framing.**

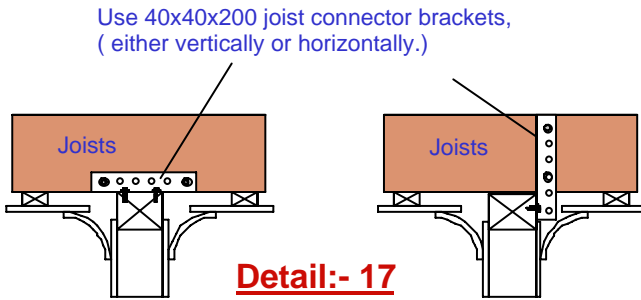

**Connections to load bearing walls**

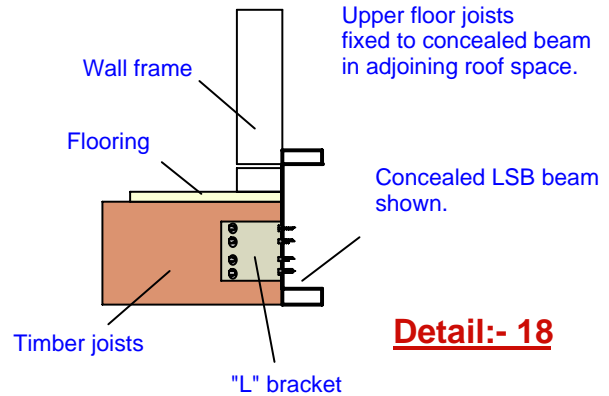

**Connection to concealed LSB beam.**

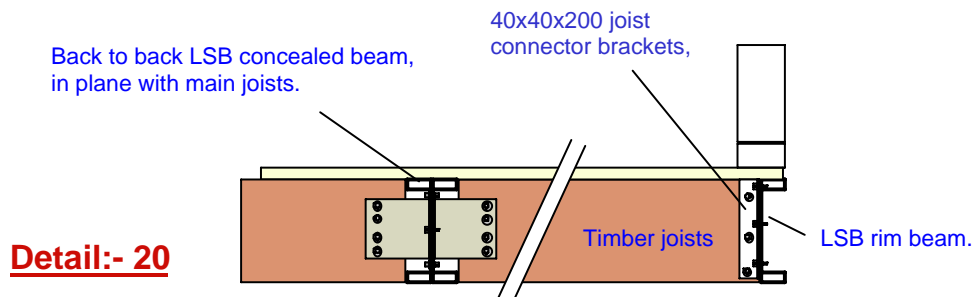
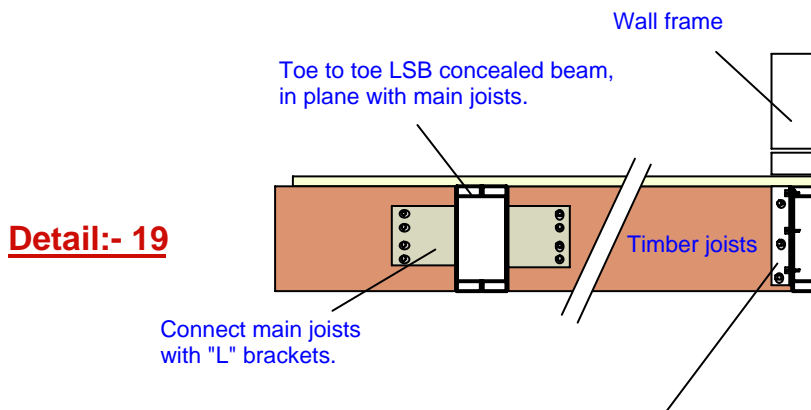

**Connection of in-plane joists with concealed LSB beams.**

## **Upper floor details**

# Steel - MAX

Building Systems  
www.steelmax.com.au

**"The right choice"**

## **Steel-MAX companion products to suit TIMBER floor framing.**

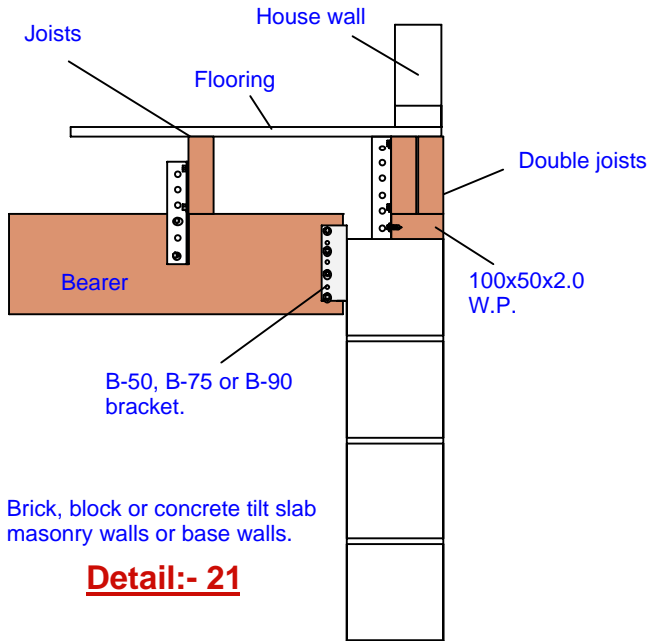

**Detail:- 21**

Fully coat all members exposed to corrosive elements with wattle Supaprime paint or equivalent.

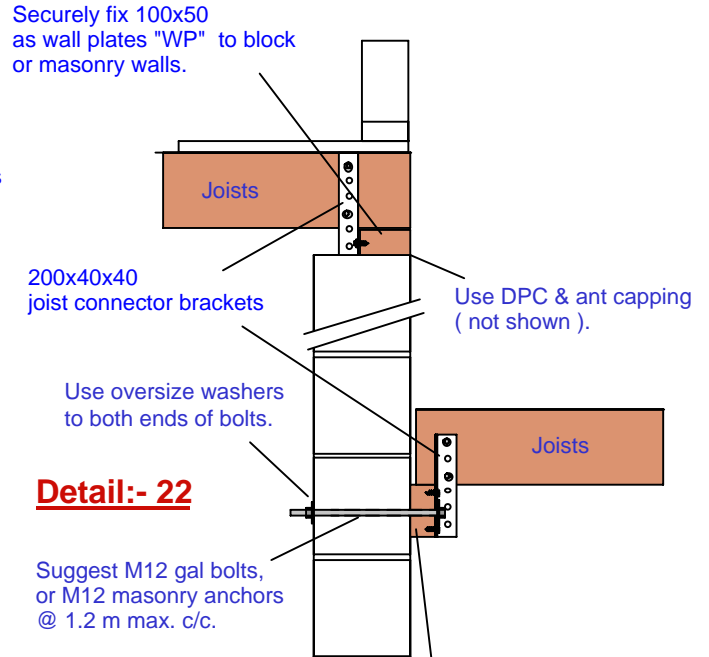

**Detail:- 22**

Suggest M12 gal bolts, or M12 masonry anchors @ 1.2 m max. c/c.

Securely fix 100x50 as wall plates "WP" to block or masonry walls.

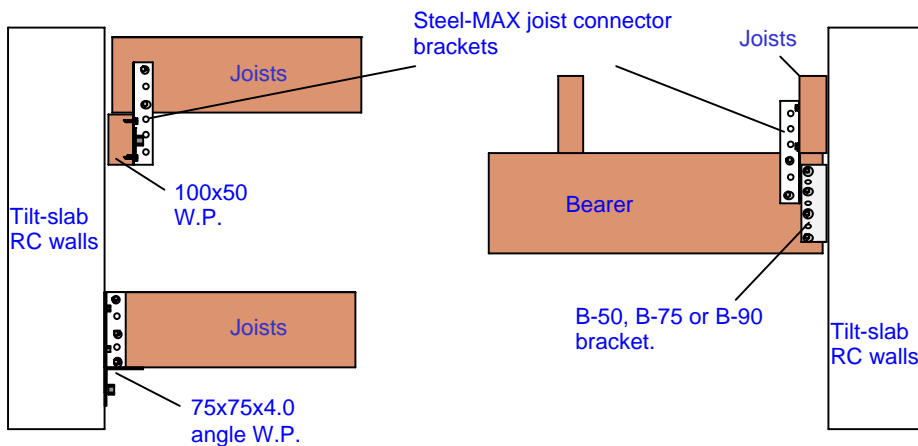

**Detail:- 23**

**Detail:- 24**

## **Connections to masonry walls**

## **Structural Load capacities for "Smart stumps" and connections.**

### **Steel stump tube:**

( Minimum grade C350 )

SHS	Max. height
75x2.0	= 1.8m
75x2.5	= 2.5m
75x4.0	= 3.4m

SHS	Max. height
89x2.0	= 3.0m
89x3.5	= 4.0m
89x5.0	= 4.8m
89x6.0	= 5.5m

### **Stump tops to steel stump tube:**

( Minimum stump top and post Yield Stress  $f_y = 300$  MPa; Minimum bolt Yield Stress  $f_y = 400$ MPa )

Connection	Shear capacity $V_u$
2x14-20 Tekes	14.7kN
4x14-20 Tekes	29.4kN
8x14-20 Tekes	58.8kN
16x14-20 Tekes	117.6kN
20x14-20 Tekes	147.0kN
1 / M12 bolt	24.2kN
2 / M12 bolts	48.4kN

Notes:-

1. All shear capacities are governed by the screw/bolt shear capacity.
2. Calculations based on a minimum post wall thickness of 2.0mm.
3. Tek screws to be installed in accordance with the manufacturer's specifications
4. Screws and bolts may be combined to achieve reduced shear capacities, using the appropriate reduction factors for each connection type.

### **Stump top to timber bearer connection**

( Minimum stump top, fin plate Yield Stress  $f_y = 300$  MPa; Minimum bolt Yield Stress  $f_y = 400$ MPa )

Connection	Shear capacity $V_u$
2 / No. 14 Type 17 batten screws	5.3kN
3 / No. 14 Type 17 batten screws	7.9kN
4 / No. 14 Type 17 batten screws	10.6kN
1 / M12 bolt	9.6kN

Notes:-

1. All capacities are based on a minimum timber joint group - JD4
2. Calculations based on a minimum timber thickness of 45mm.
3. Minimum edge distance and spacing of bolts to be 60mm.
4. Minimum edge distance of screws - 31.5mm.
5. Minimum spacing of screws across grain - 20mm.
6. Minimum spacing of screws along grain - 65mm.
7. Minimum penetration of screw - 45mm.
8. Domestic or secondary element capacity factor ( $\phi$ ) of 0.75 for timber.

### **B-50, 75 & 90 wall brackets to timber bearer connection**

( Design based on 2 / M12 chemset injection anchor fixing of bracket to core-filled masonry wall of 15MPa )

Connection	Shear capacity $V_u$
2x14-20 Tekes	9.2kN
4x14-20 Tekes	18.4kN
6x14-20 Tekes	27.6kN
1 / M12 bolt	10.2kN
2 / M12 bolts	20.4kN

Notes:-

1. All shear capacities are governed by the hole capacity of the RHS's web and not the screw/bolt shear capacity.
2. Calculations based on a minimum web thickness of 1.5mm, minimum Tensile Strength ( $f_u$ ) = 490MPa and minimum Yield Stress ( $f_y$ ) = 380MPa.
3. Tek screws to be installed in accordance with the manufacturer's specifications
4. RHS members to be fully restrained against lateral displacement of both flanges and twisting about the longitudinal axis.

### **Bracing brackets**

Connection	Bracing capacity
4x14-20 Tekes	15kN ( 12mm rod )
M16 bolt	22kN ( 16mm rod )

### **Moment base plates**

Notes:-

- 100x100x4.0 Moment Base Plates have an ultimate bending moment capacity of 5.2kNm, subject to the following:-
1. Must be fixed to a footing or slab with a minimum compressive strength of 25MPa with 4 / M12 chemset anchors, fixed with a minimum distance between the centre of the bolt and the edge of slab of 50mm.
  2. The supporting structure should be assessed by the project engineer to ensure that it is structurally capable of withstanding both the moment and vertical loads expected.
  3. The Moment sleeve must be fixed to the supported post with a No.10 Tek screw in each of the four faces of the sleeve.
  4. The gap between the sleeve and the supported post must be adequately sealed to prevent moisture ingress between the two members.

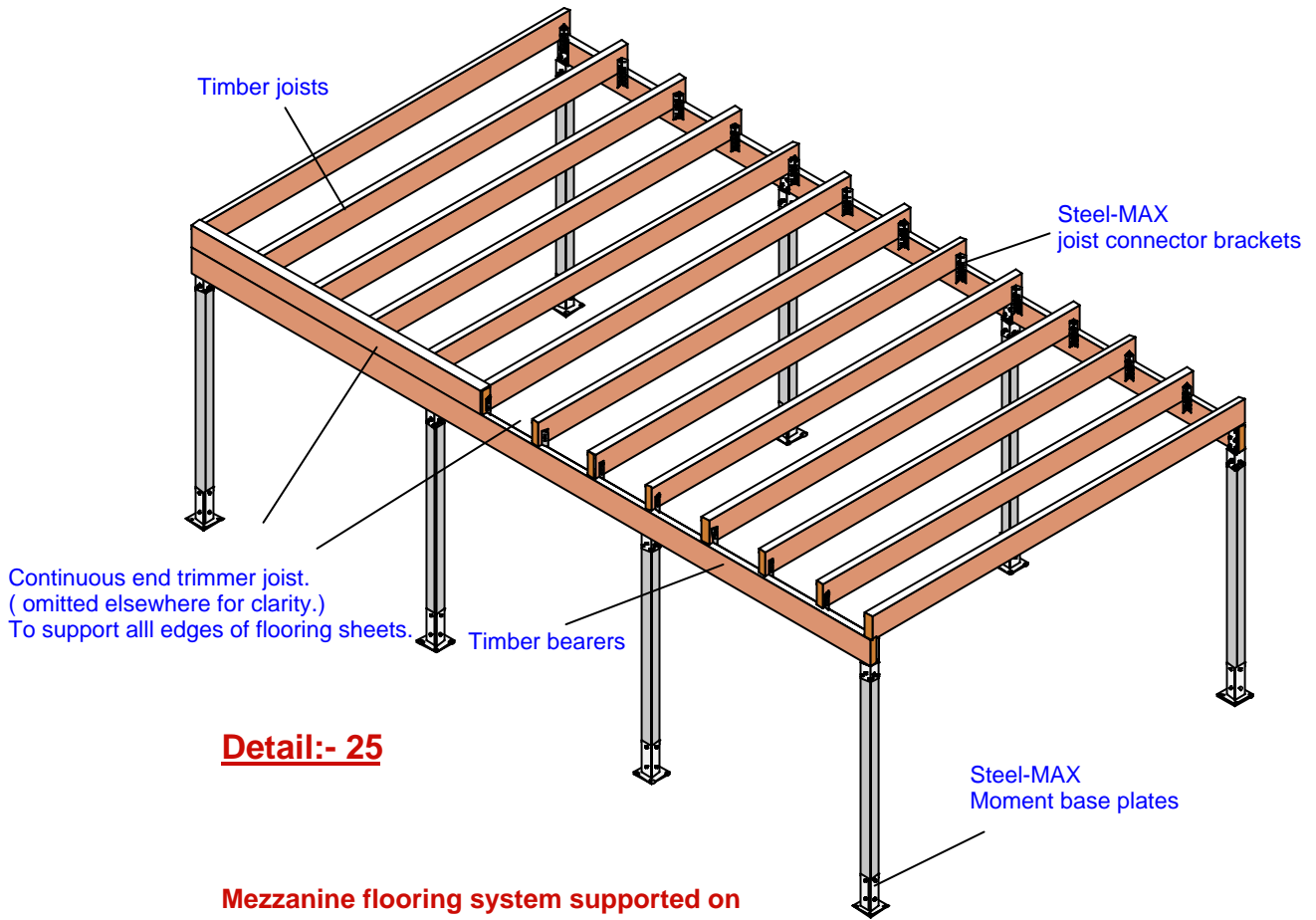

**Detail:- 25**

**Mezzanine flooring system supported on Steel-MAX 89mm "Smart stumps" with Moment Base plates.**

**Mezzanine floors**

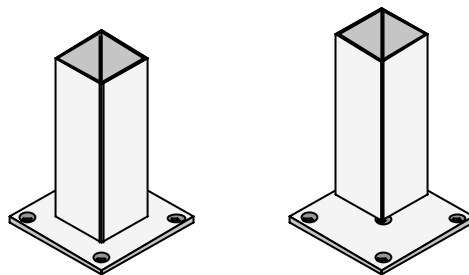

Moment base plates

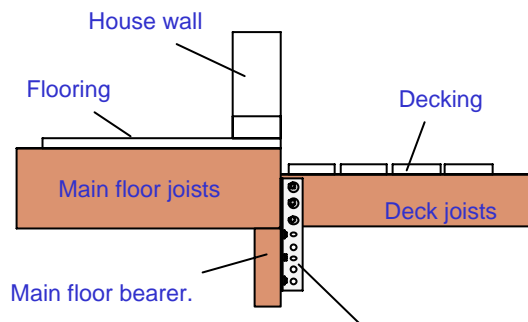
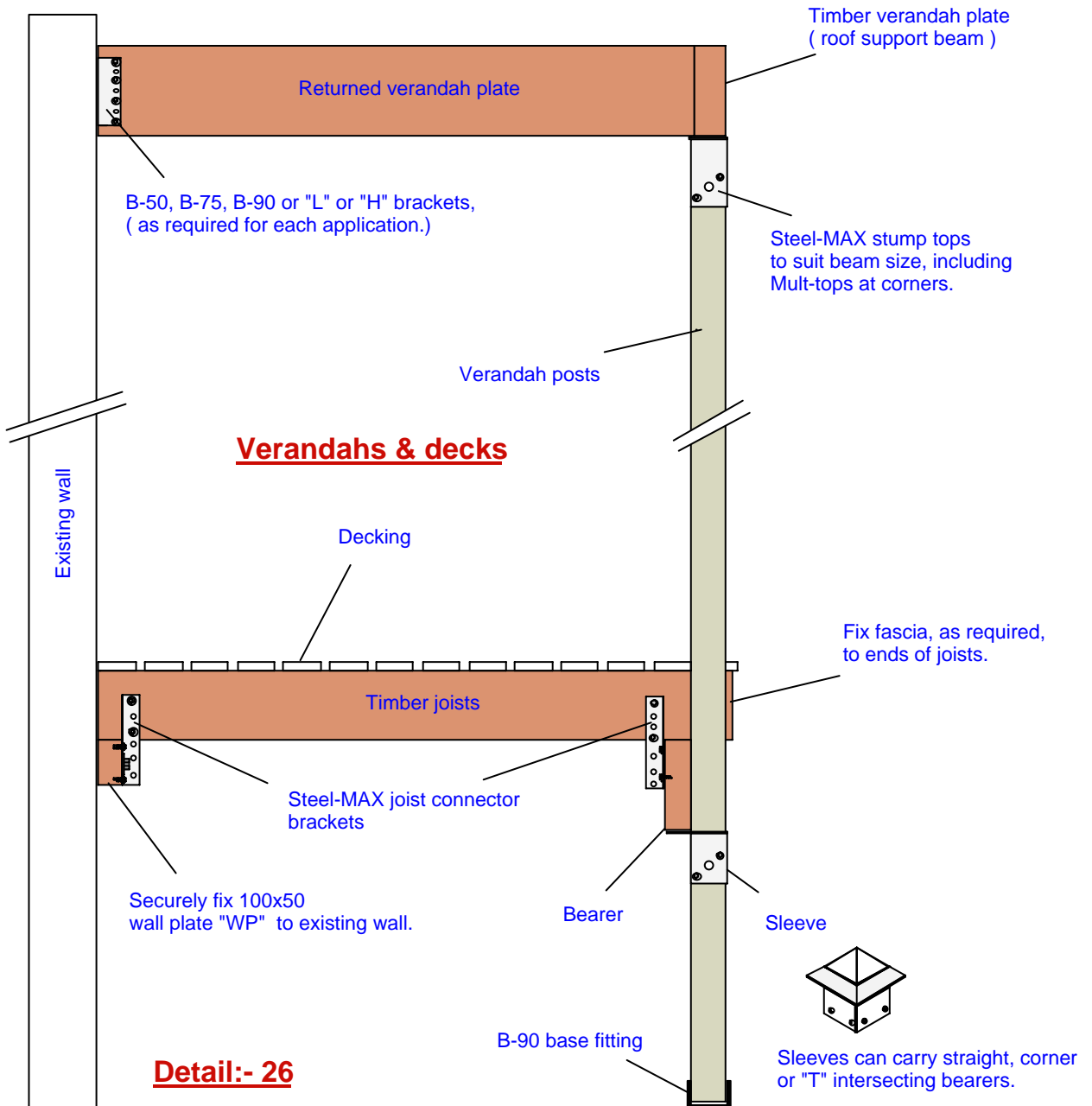

**Connection of deck joists to main floor.**

Stump tops can also be used on top of verandah posts to carry steel or timber verandah plates ( beams ).

As with stump applications, Multi-tops can be used at corners to take returned or intersecting beams.

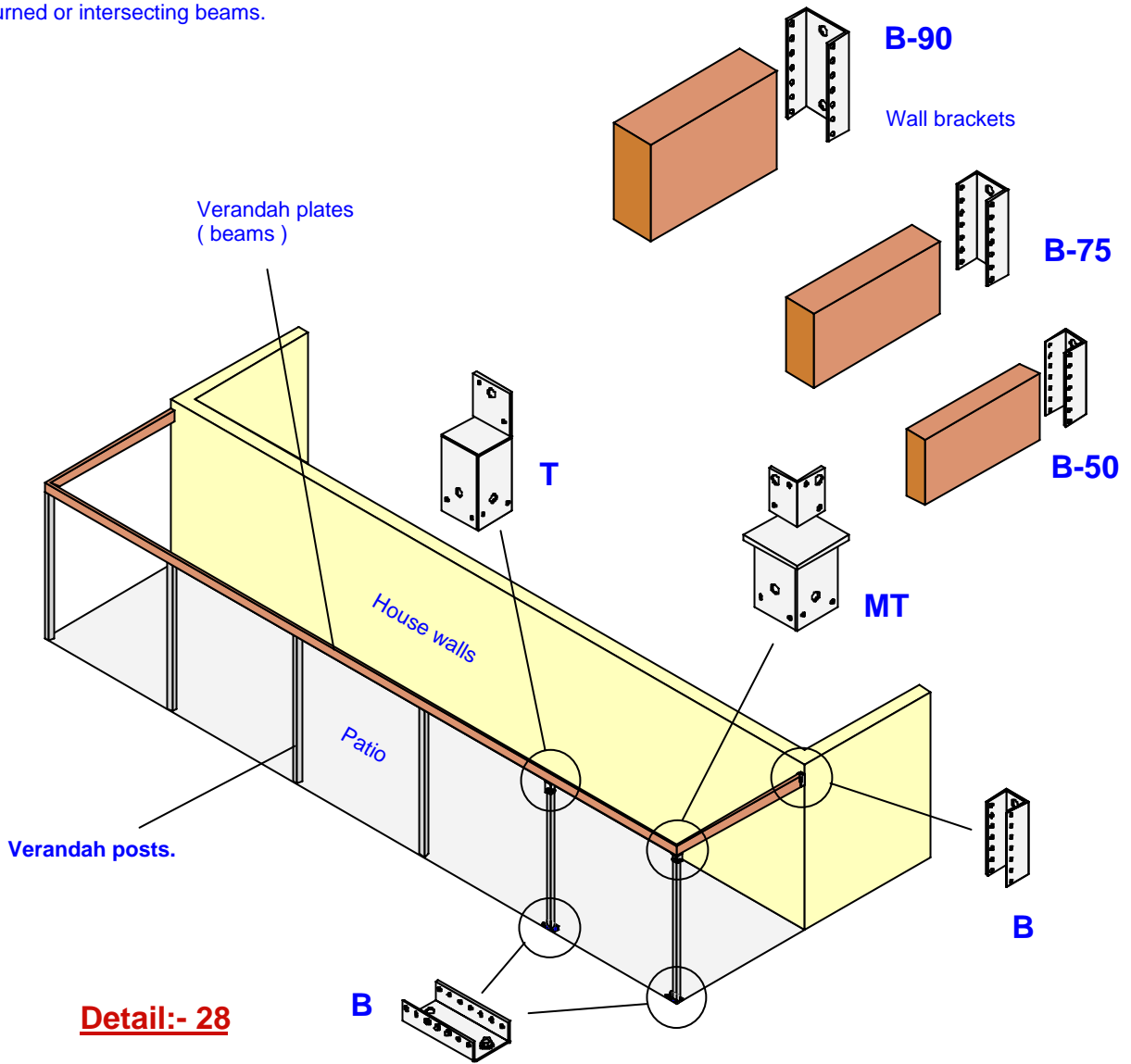

## **Verandahs & decks**

# Steel - MAX

Building Systems  
www.steelmax.com.au

**"The right choice"**

## Steel-MAX companion products to suit TIMBER floor framing.

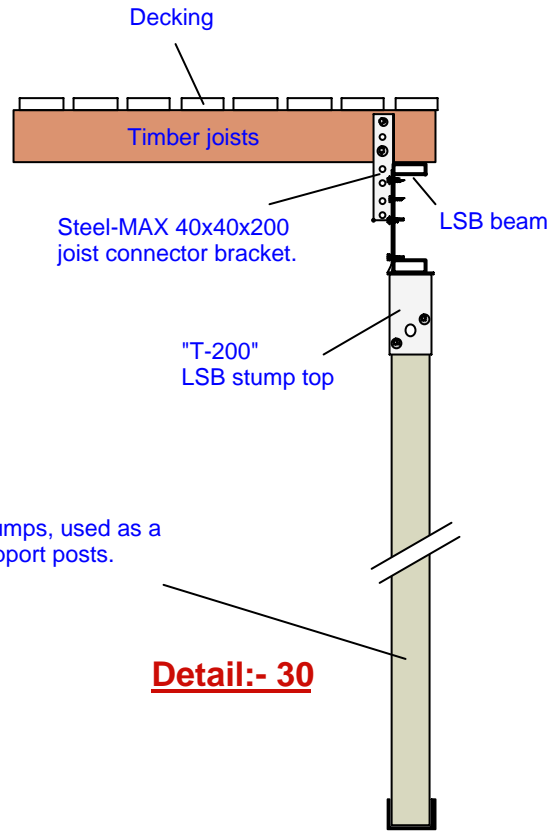
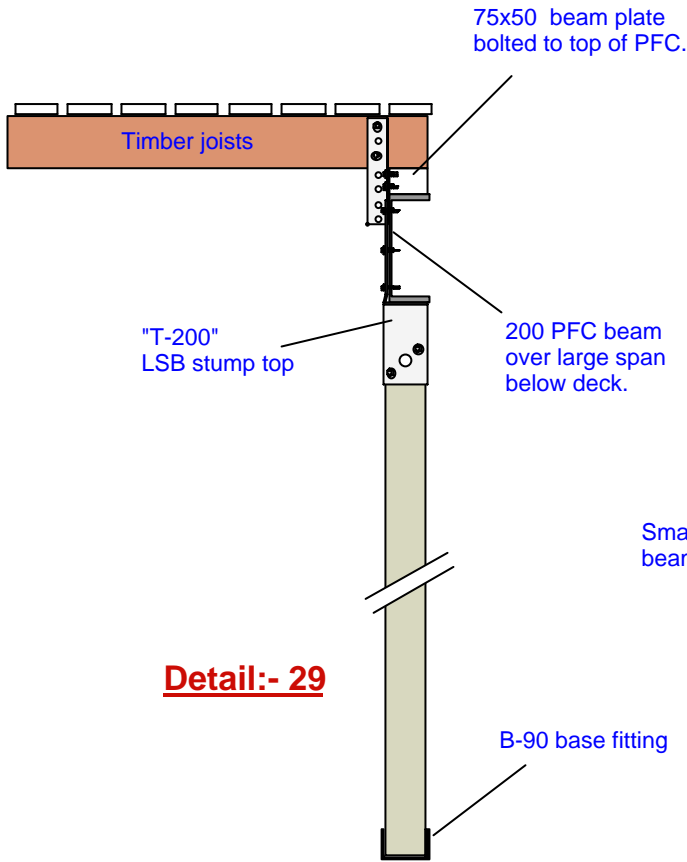

### Verandahs & decks

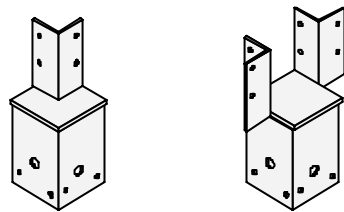

**Special 50mm set-back Multi-tops**  
Multi-fit, to allow for flush 50mm wide bearers

**Detail:- 31**

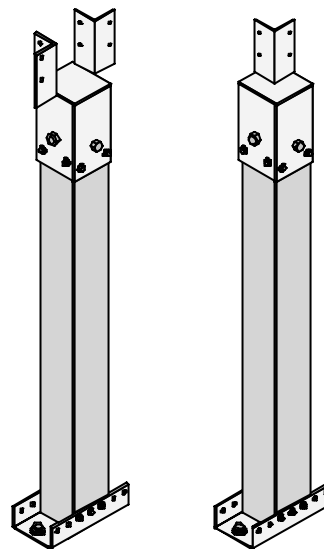

### Special "Flush fitting" Multi-tops.

# Steel - MAX

Building Systems  
www.steelmax.com.au

**"The right choice"**

## **Steel-MAX companion products to suit TIMBER floor framing.**

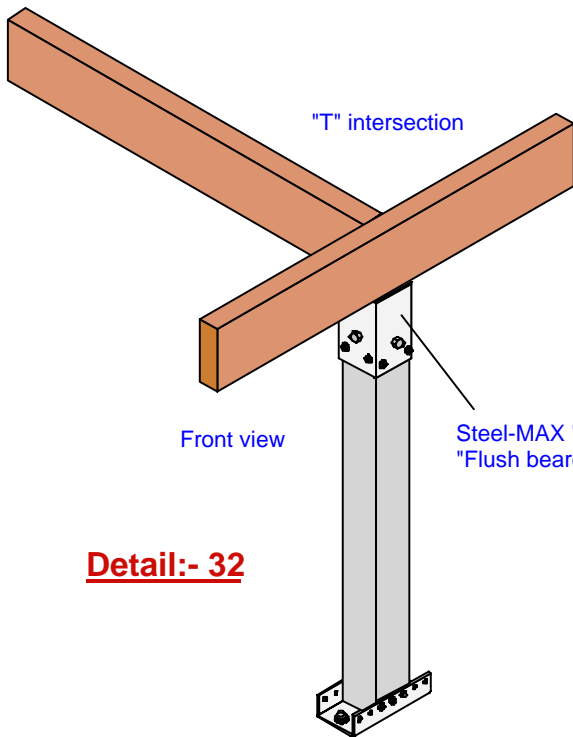

"MT-DT" carries 100mm wide or double 50mm wide bearers in straight runs or at "T" intersections with other bearers.

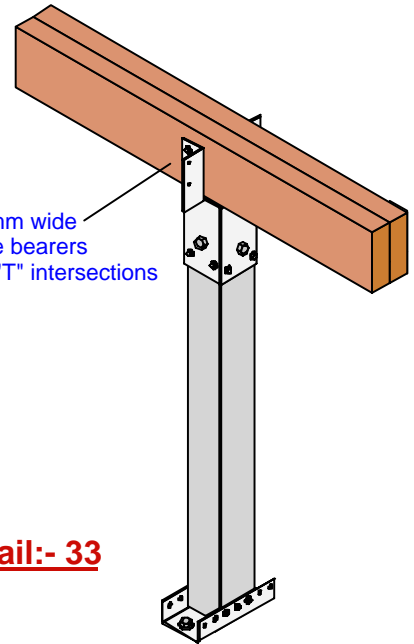

Useful for verandahs & decks, where bearers need to be flush with face of stumps and act as "fascia-beams".  
Joists can also be fixed in-plane to back face of bearers with joist hangers or similar.

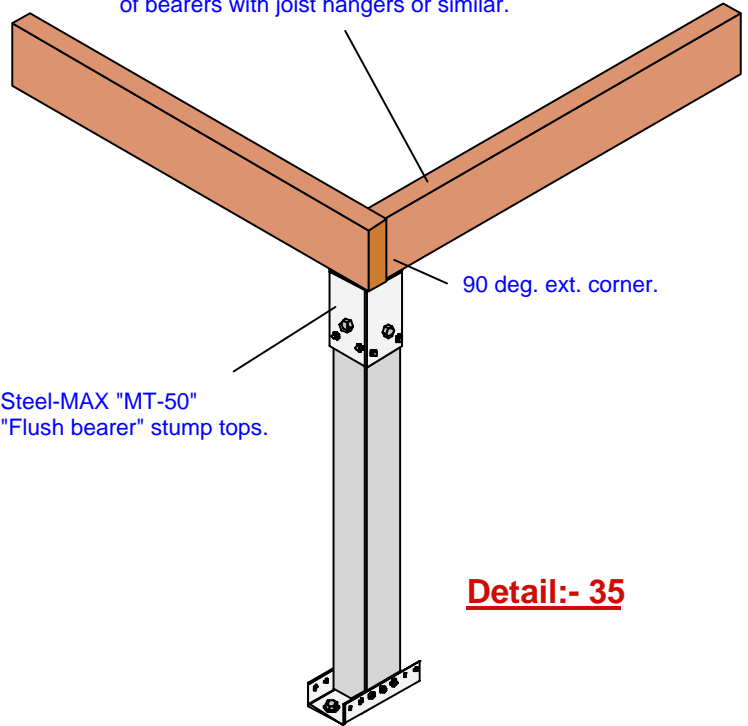
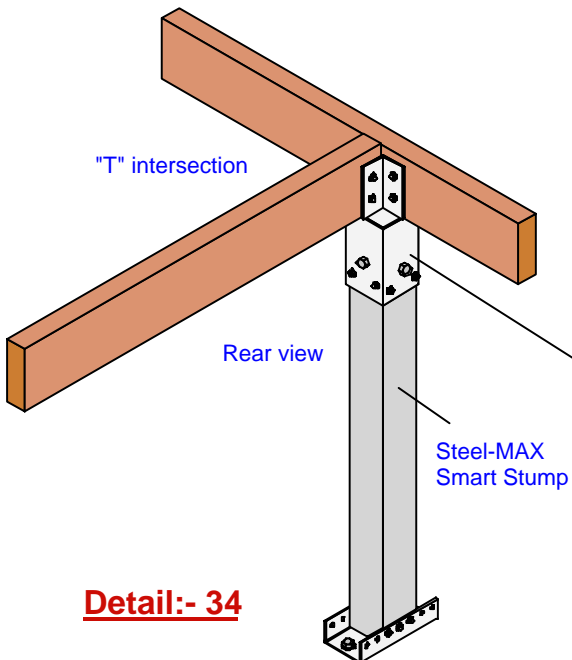

## **Special "Flush fitting" Multi-tops to suit 50mm wide bearers or beams.**

# Steel - MAX

Building Systems  
www.steelmax.com.au

**"The right choice"**

**Steel-MAX companion products  
to suit TIMBER floor framing.**

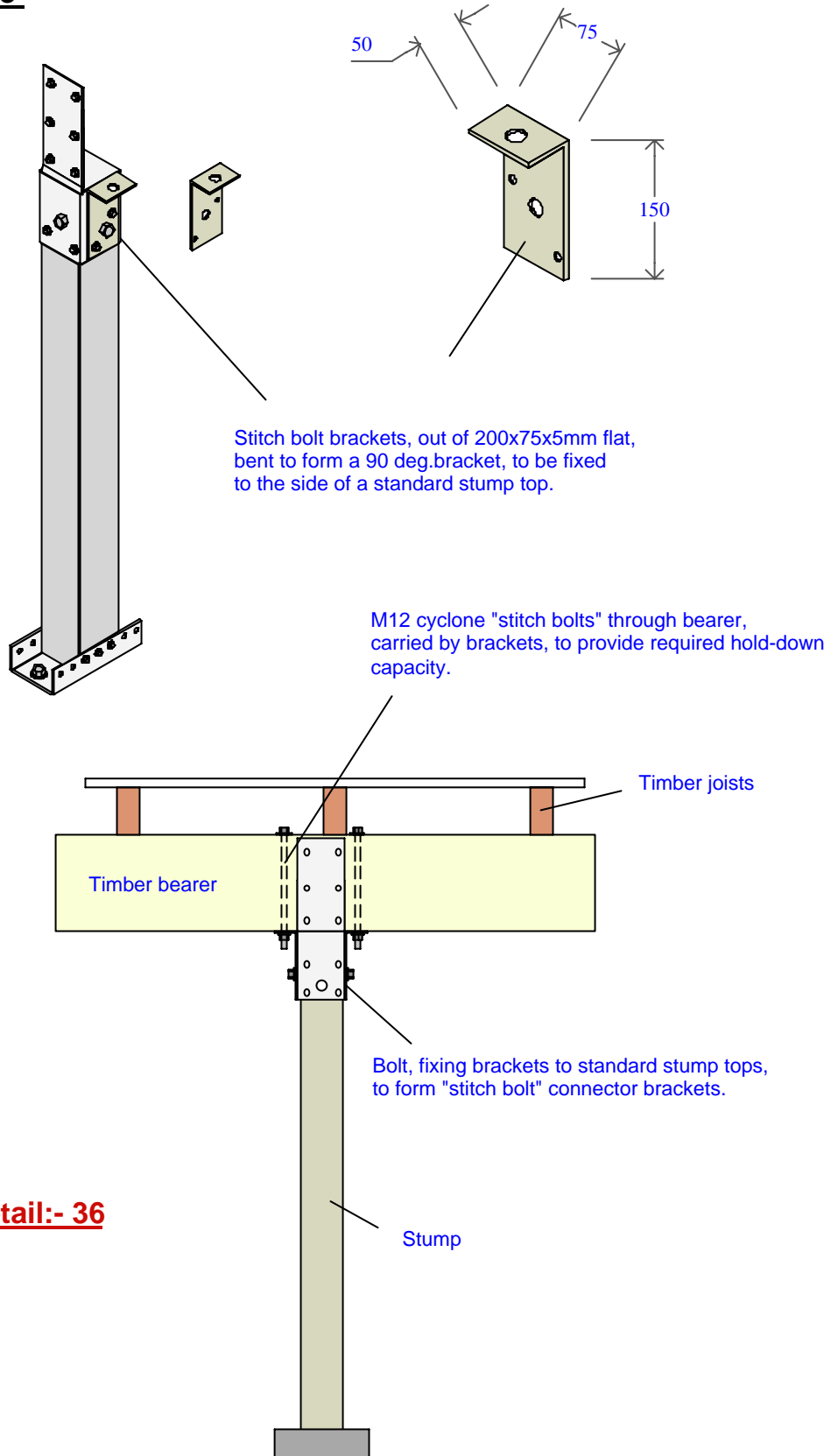

**Timber bearer cyclone bolt brackets.**